

ETS Heavy Duty Rotary Electric Vibrators 4 Poles - 1800 RPM @ 60 HZ 230/460 3 Phase

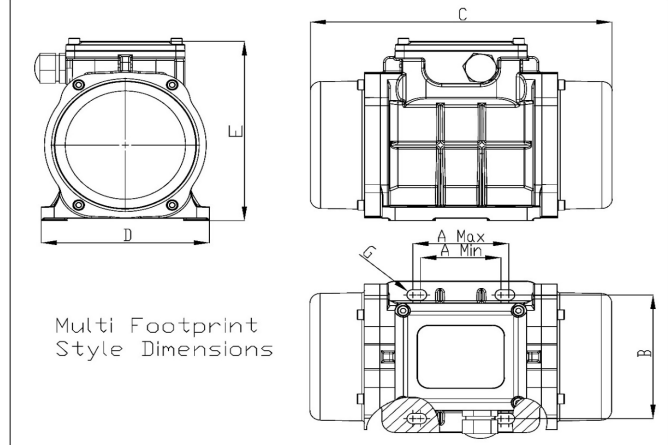

Questions contact us at: 814-899-2103
 Email: info@erietechnicalsystems.com
 website: www.bulkfilling.com

DIMENSIONAL INFORMATION (All Dimensions are in Inches)									Technical Information		Force and Weight Information	
MODEL	OLI Model Number	A	B	G (Hole Dia.)	# Of HOLES	C	D	E	INPUT HP	UNBALANCE (IN*LB)	Force Output (Pounds)	Weight (Pounds)
ETS 70/4E	MVE 70/4E-10A0	Multiple Footprint			4	8.39	5.12	5.31	0.05	0.86	79	10
		2.44-2.91	4.17	0.35								
		1.30	3.27-4.02	0.28								
ETS 200/4E	MVE 200/4E-20A0	Multiple Footprint			4	8.74	6.46	5.51	1.13	1.82	168	16
		2.56	5.51	0.51								
		4.53	5.31	0.43								
ETS 400/4E	MVE 400/4E-30A0	Multiple Footprint			4	10.79	5.91	6.81	0.19	4.7	432	26
		3.15	4.43	0.43								
		3.54	4.92	0.51								
ETS 750/4E	MVE 750/4E-51A0	4.72	6.69	0.67	4	12.64	8.19	8.27	0.98	8.07	741	49
ETS 860/4E	MVE 860/4E-40A0	4.13	5.51	0.51	4	12.99	6.69	7.72	0.43	10.15	933	43
ETS 1150/4E	MVE 1150/4E-40A0	4.13	5.51	0.51	4	12.99	6.69	7.72	0.54	12.19	1,120	46
ETS 1530/4E	MVE 1530/4E-50A0	4.72	6.69	0.67	4	15.39	8.19	8.27	0.98	17.08	1,570	60
ETS 2100/4E	MVE 2100/4E-50A0	4.72	6.69	0.67	4	17.91	8.19	8.27	1.03	22.96	2,110	73
ETS 2300/4E	MVE 2300/4E-50A0	4.72	6.69	0.67	4	17.91	8.19	8.27	1.03	26.64	2,474	78
ETS 3100/4E	MVE 3100/4E-60A0	5.51	7.48	0.67	4	17.56	9.06	10.24	1.13	33.3	3,060	134
ETS 3880/4E	MVE 3880/4E-60A0	5.51	7.48	0.67	4	17.56	9.06	10.24	1.74	39.92	3,668	131
ETS 5340/4E	MVE 5340/4E-60A0	5.51	7.48	0.67	4	17.56	9.06	10.24	2.53	59.62	5,478	137
ETS 5700/4E	MVE 5700/4E-70A0	6.10	8.86	0.87	4	19.72	10.83	11.42	3.08	58.87	5,410	164
ETS 6480/4E	MVE 6480/4E-70A0	6.10	8.86	0.87	4	19.72	10.83	11.42	3.68	73.68	6,770	164
ETS 8400/4E	MVE 8400/4E-75A0	6.10	10.04	0.93	4	21.10	11.97	12.36	4.15	88.86	8,166	322
ETS 9480/4E	MVE 9480/4E-75A0	6.10	10.04	0.93	4	22.20	11.97	12.36	4.5	104.58	9,610	275
ETS 12260/4E	MVE 12260/4E-85A0	7.09	11.02	1.02	4	23.74	13.07	14.17	4.63	131.83	12,114	373
ETS 15850/4E	MVE 15850/4E-85A0	7.87	12.6	1.10	4	24.57	15.16	15.83	8.72	172.45	15,847	509
ETS 19800/4E	MVE 19800/4E85A0	7.87	12.6	1.10	4	24.57	15.16	15.83	11	216.47	20,221	531
ETS 21000/4E	MVE 21000/4E-90A0	4.92	14.96	1.54	6*	28.66	17.8	16.34	13.1	255.34	23,464	631
ETS 26100/4E	MVE 26100/4E-100A0	5.51	17.32	1.77	6*	35.04	20.87	19.06	15.5	284.45	26,131	930
ETS 33400/4E	MVE 33400/4E-100A0	5.51	17.32	1.77	6*	35.04	20.87	19.06	18.5	363.55	33,406	974

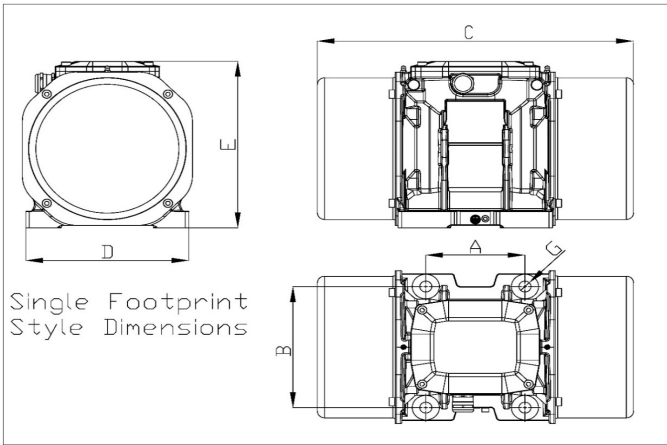

* For 6 and 8 hole vibrators the "A" dimension is the center distance between each hole

All Vibrators are designed and tested to conform to Class II, Div 2, Group F&G electrical area classifications.
 Motors operate at < 60 Decibels.
 All Dimensions subject to change without notice.
 All weights are adjustable from 0-100% force output.
 All motors are rated continuous duty at Maximum setting.